

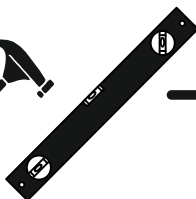

MULTIMO

151-SLIDING SUIT

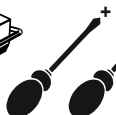

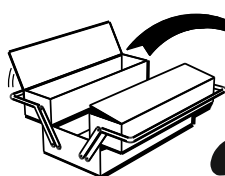
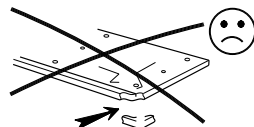
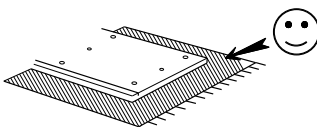
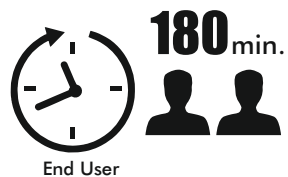
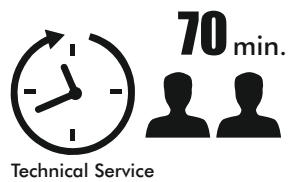
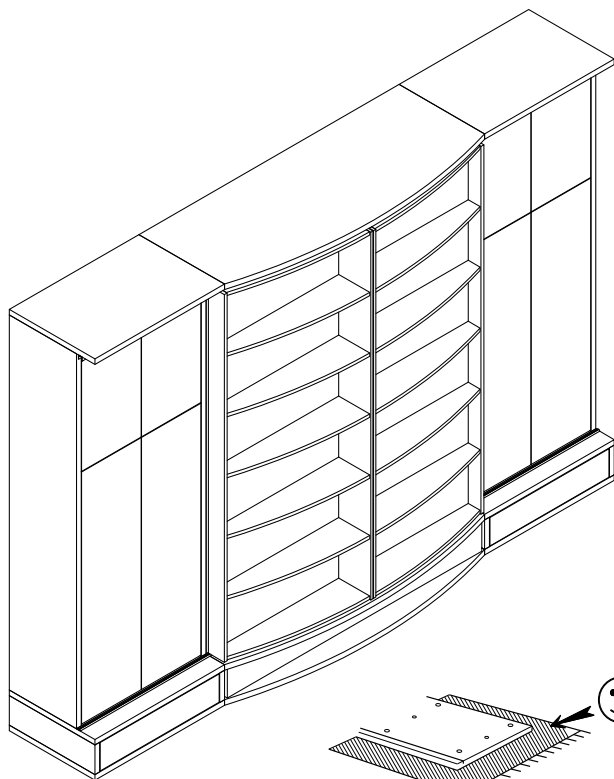

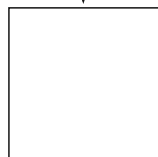



VIDEO

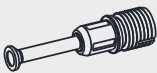

link

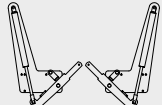
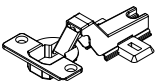
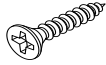
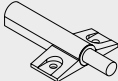
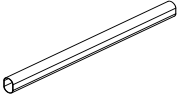
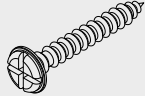
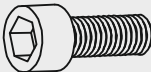
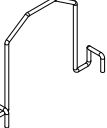
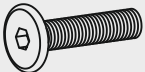
Track Title	Piece	(inch)			(mm)			
		Thickness	Length	Width	Piece	Thick	Height	Most
A	1	1,18	58,90	25,79	1	30	1496	655
B	1	1,18	58,90	9,25	1	30	1496	235
C	1	1,18	58,90	25,79	1	30	1496	655
D	2	0,71	57,48	4,72	2	18	1460	120
E	2	1,18	57,48	3,94	2	30	1460	100
F	2	0,71	87,40	16,54	2	18	2220	420
G	1	0,71	58,90	6,30	1	18	1496	160
H	2	0,71	6,30	3,78	2	18	160	96
K	2	8,66	78,35	29,33	2	220	1990	745
L	4	1,18	79,92	16,54	4	30	2030	420
M	2	8,66	29,53	21,06	2	220	750	535
N	2	1,18	29,53	21,06	2	30	750	535
O	2	0,71	27,09	14,96	2	18	688	380
P	2	0,71	27,09	14,17	2	18	688	360
R	4	0,71	53,70	13,46	4	18	1364	342
S	4	0,71	24,72	13,46	4	18	628	342
U	2	0,31	80,59	27,80	2	8	2047	706
Y	3	0,31	88,07	19,33	3	8	2237	491

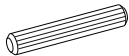
Accessories List

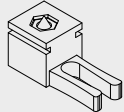
MXN 02  62 / piece VD - 03 (3,5x18) mm	MNG - 01  62 / piece B5 - 01	MKZ - 02  1 / piece 700 N BO - 01	TS - 03  20 / piece VD - 02 (3,5x25) mm
 122 / piece IM - 02 (6x20) mm	 8 / piece TTC 01	 2 / piece CT - 03 (6x50) mm	 18 / piece H 01
 4 / piece KVL 01	 6 / piece PM - 01	 8 / piece AF - 01	 2 / piece STP - 01
 70 / piece	 8 / piece	 4 / piece	 4 / piece

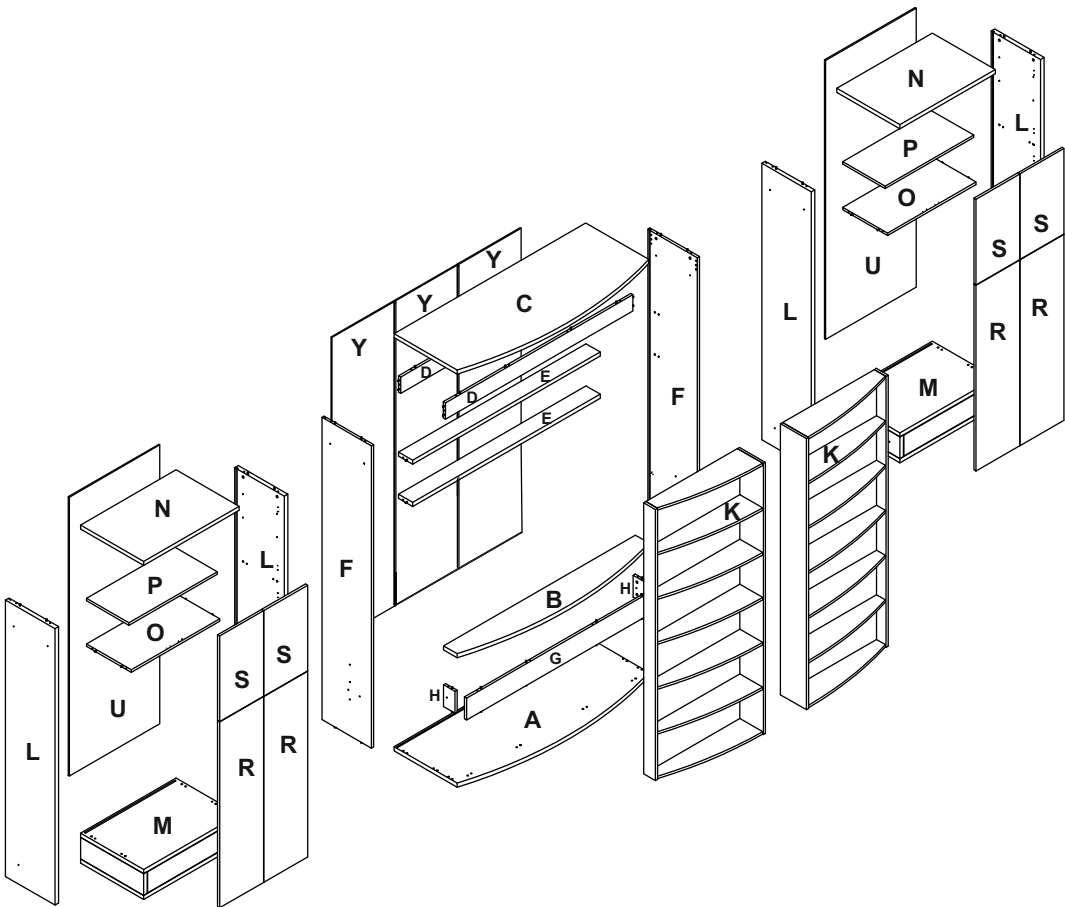

TAP - 01



62 / piece

AL - 01 (4MM)



1 / piece

AL - 02 (5MM)



1 / piece



MNX - 02

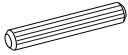

KVL 01

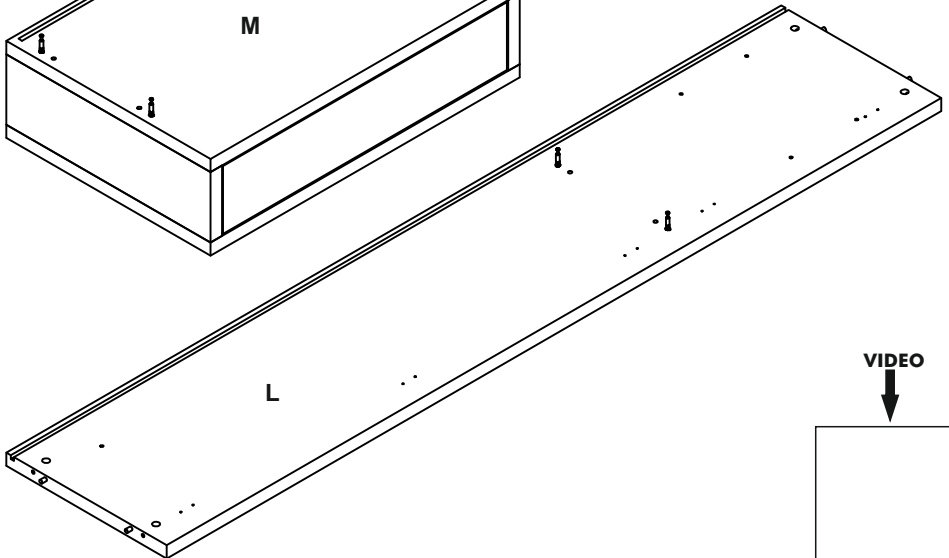
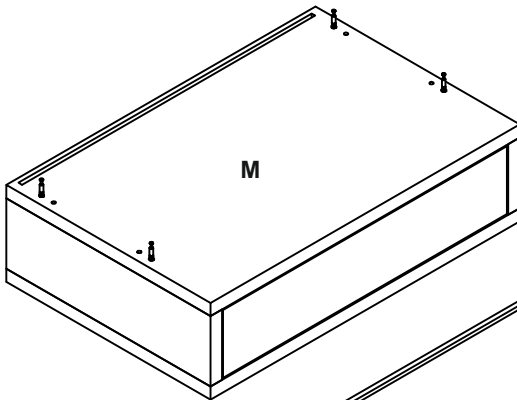
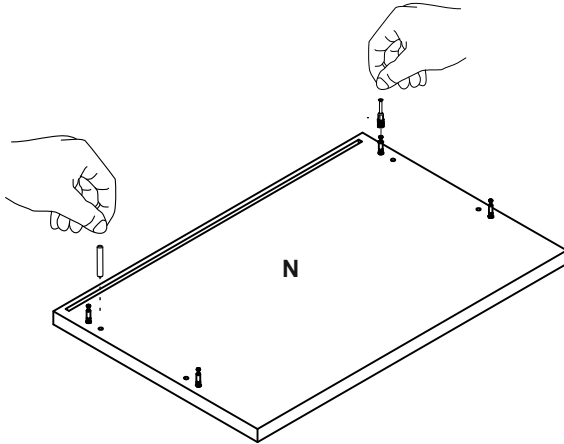

VIDEO

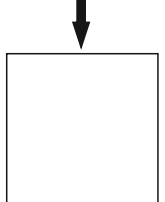

link

STEP 1



MNX - 02



KVL 01

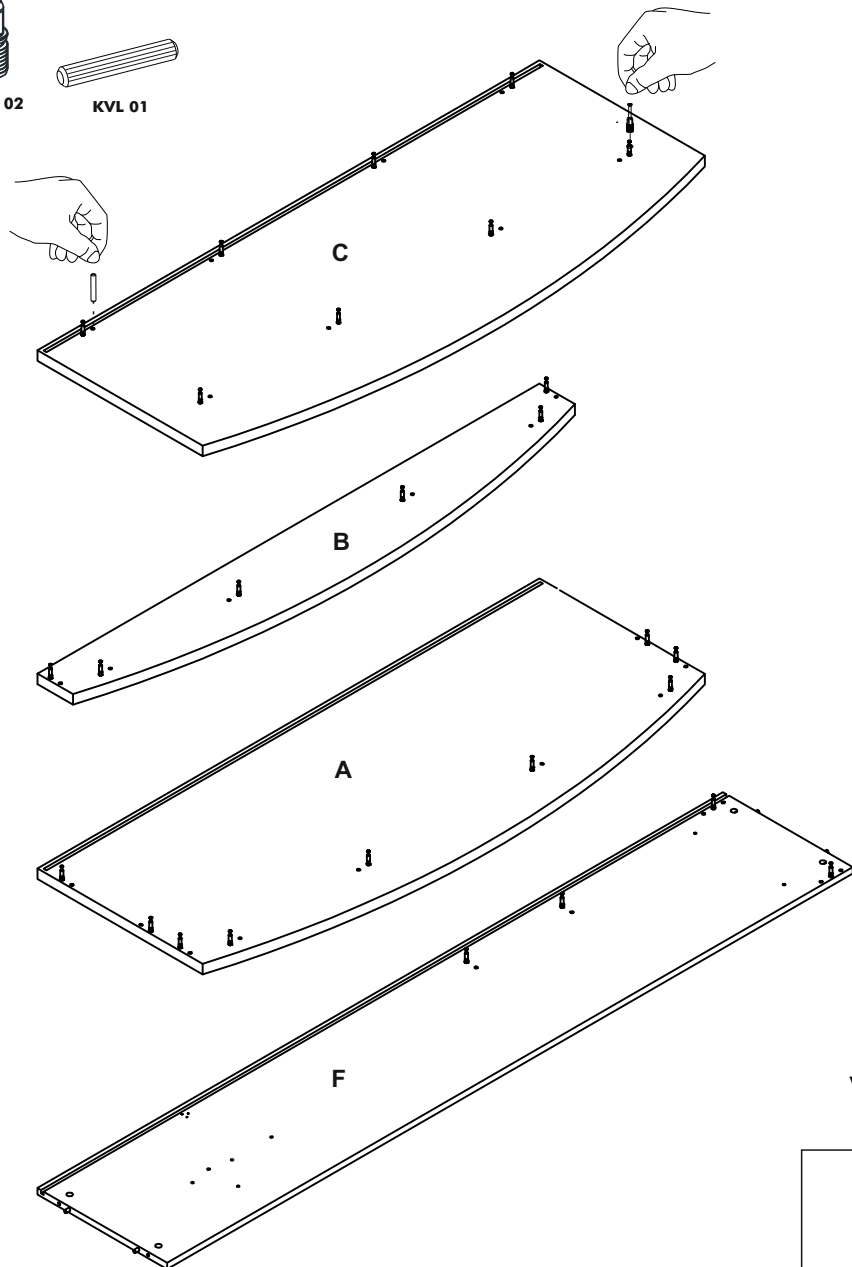

VIDEO

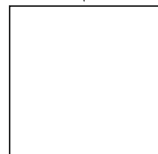

link

STEP 2

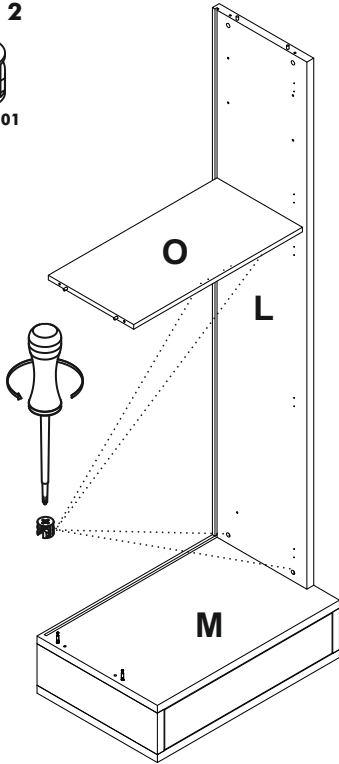

STEP 3

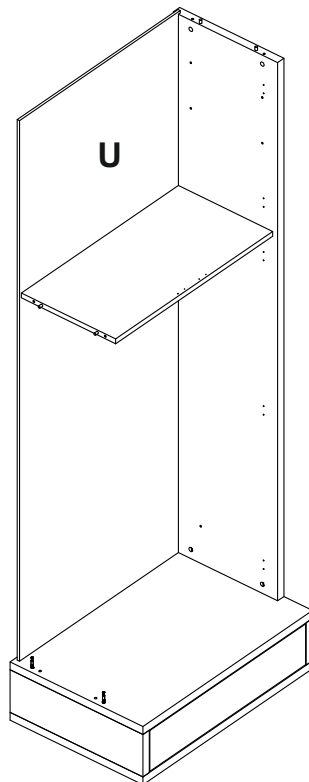

VIDEO

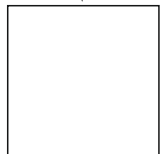

link

STEP 4



MNG - 01

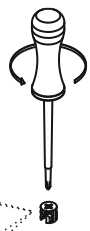
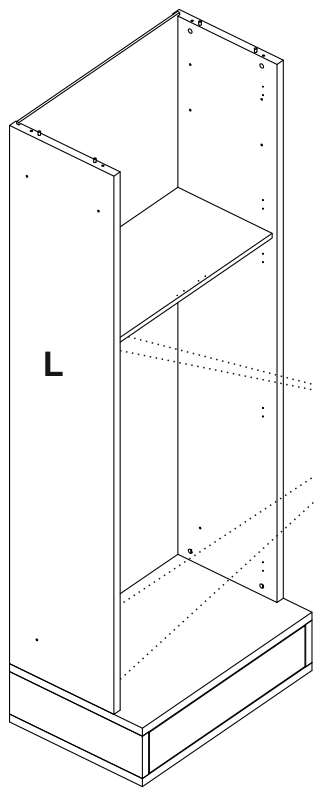

STEP 5

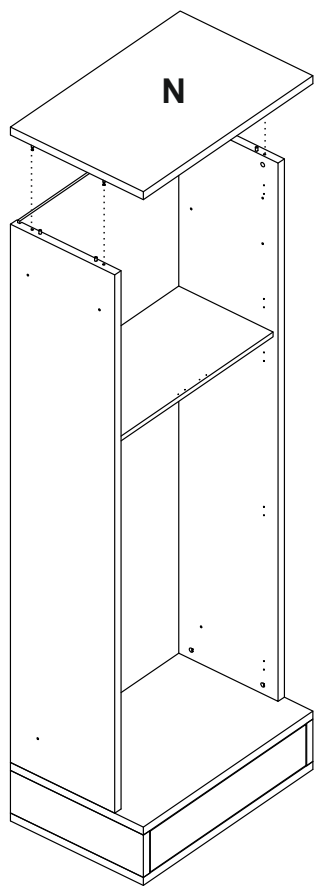

VIDEO

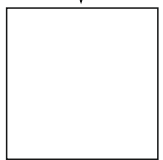

link

STEP 6



MNG - 01

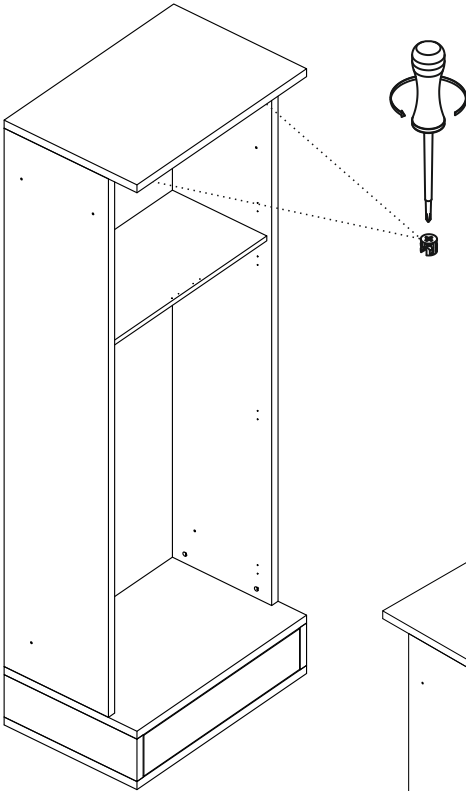

STEP 7

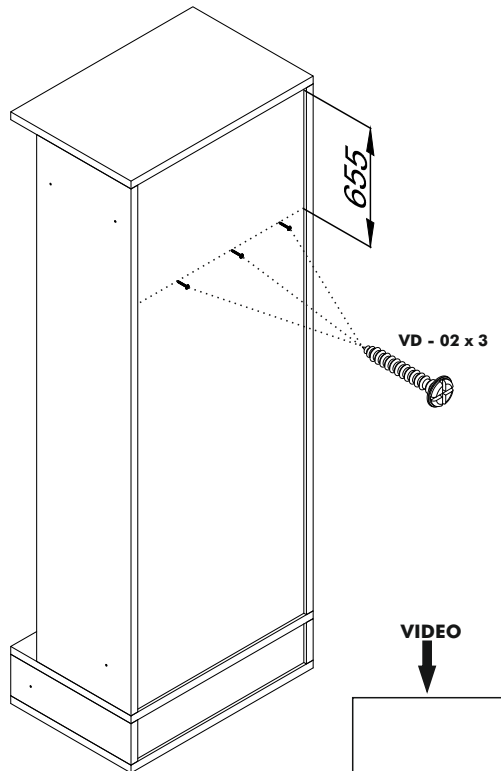

link

STEP 8



MNG - 01

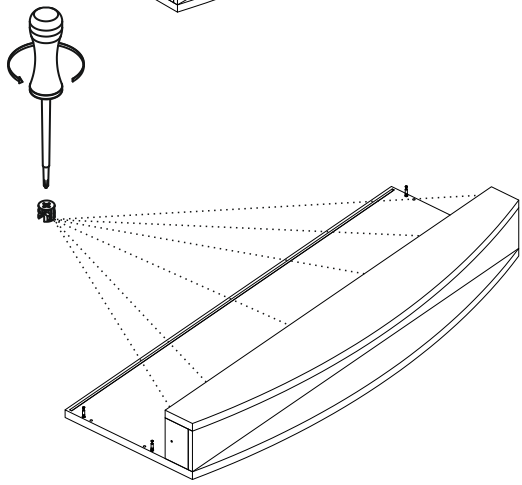
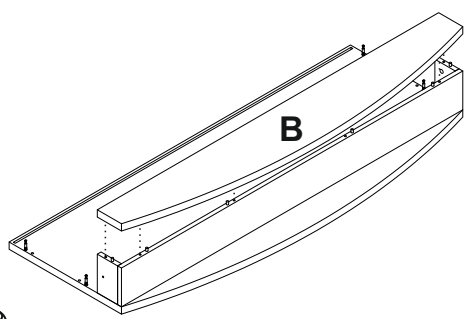
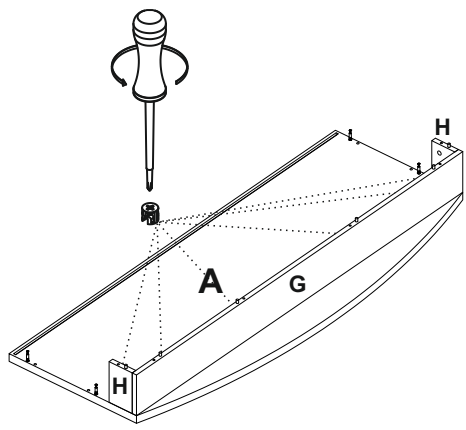

VIDEO

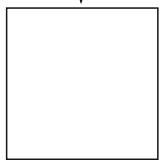

link

STEP 9



MNG - 01

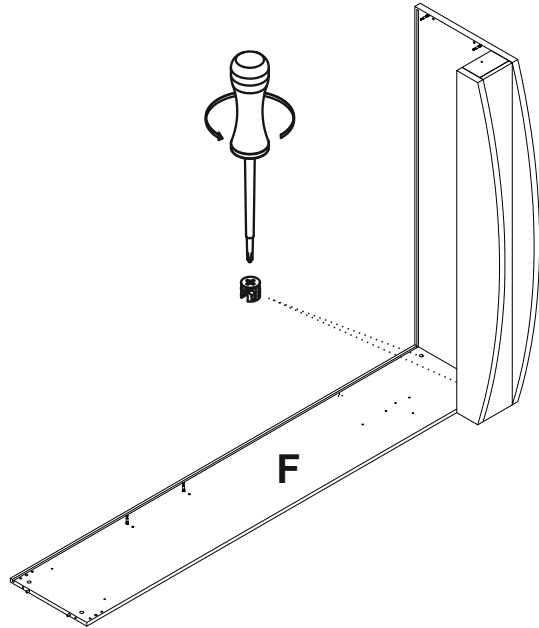

STEP 10

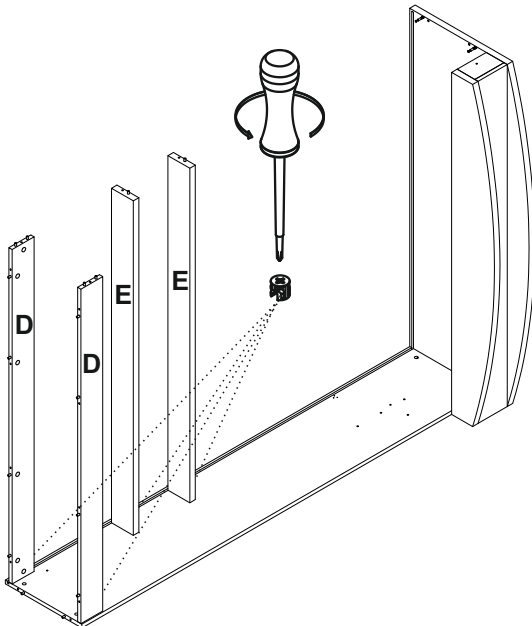

VIDEO

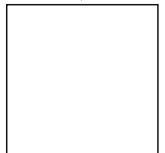

link

STEP 11



MNG - 01

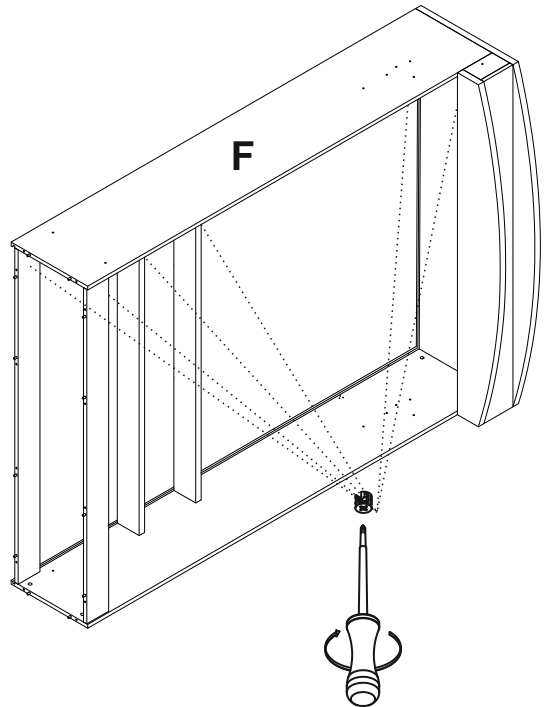

STEP 12

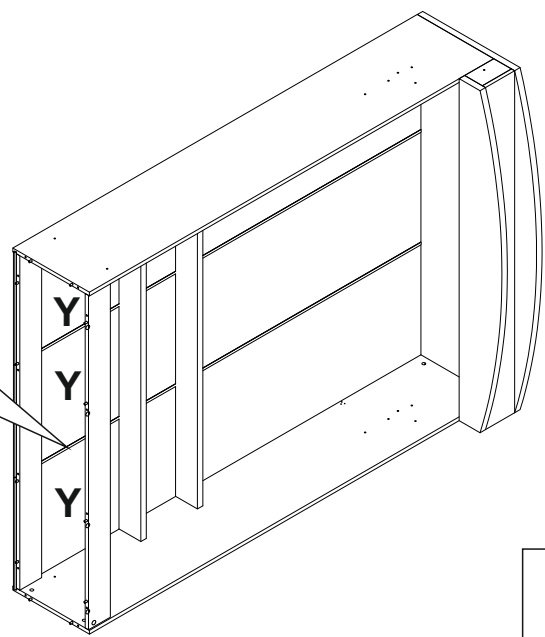
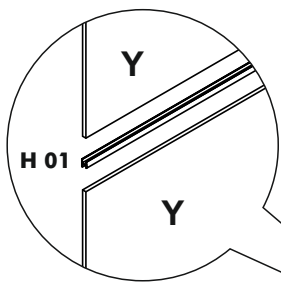

VIDEO

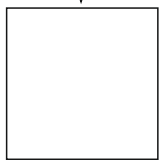

link

STEP 13



MNG - 01

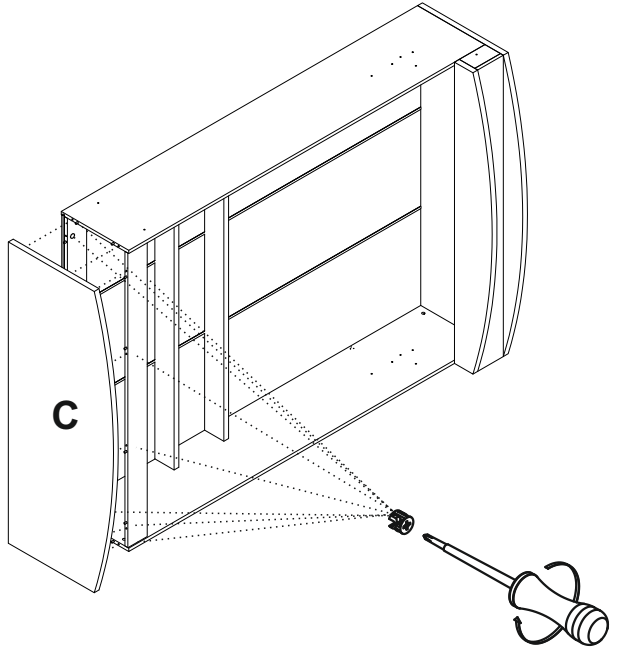

STEP 14

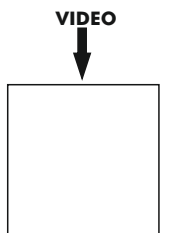
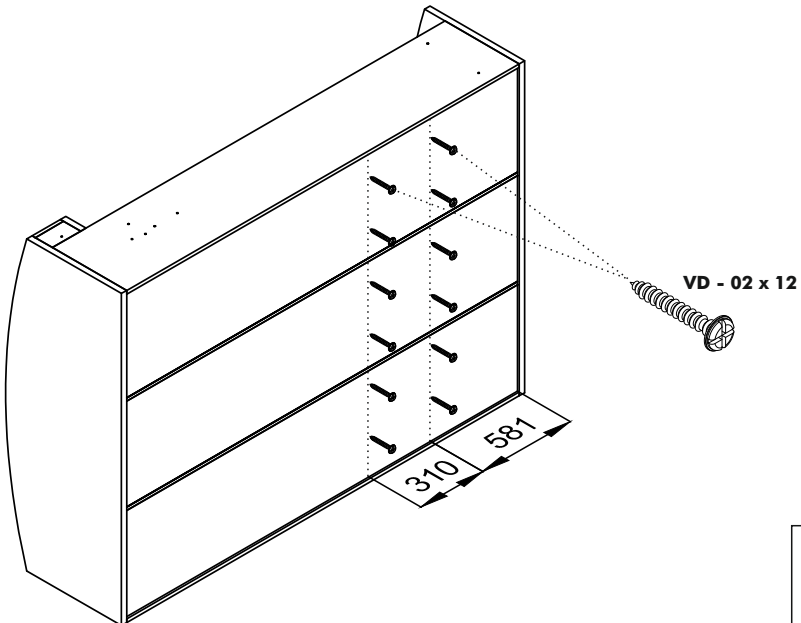

link

STEP 15

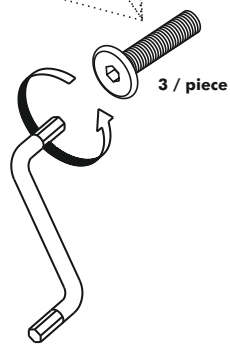
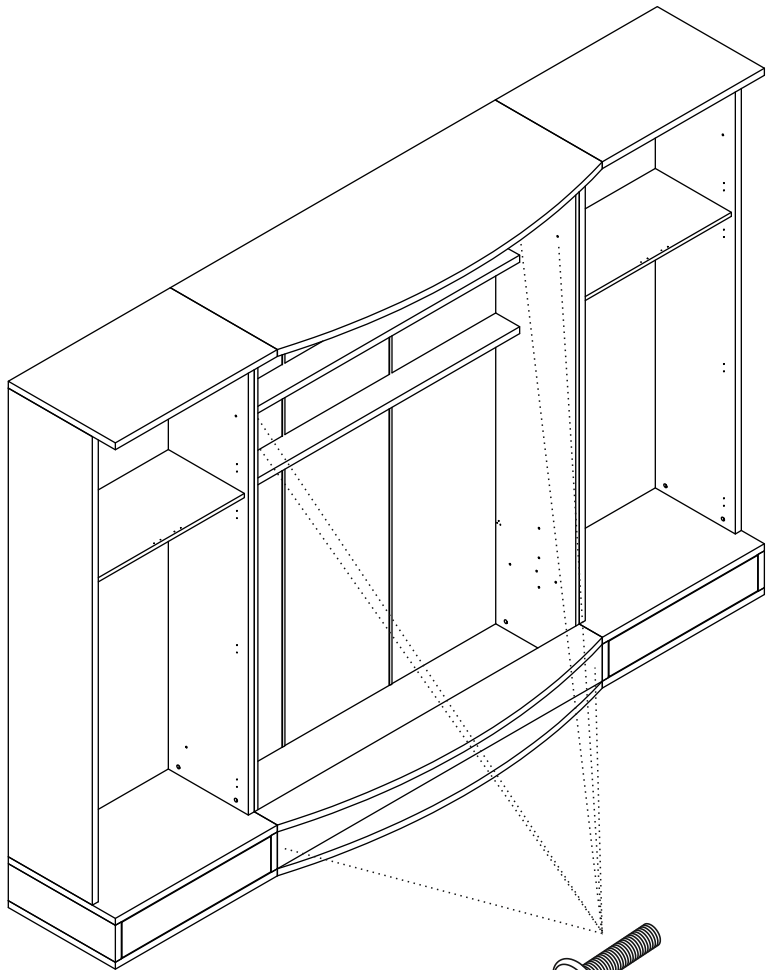

VIDEO

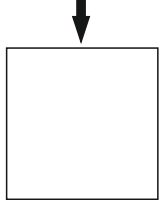

link

STEP 16

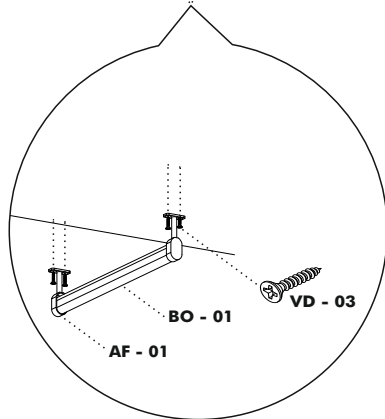
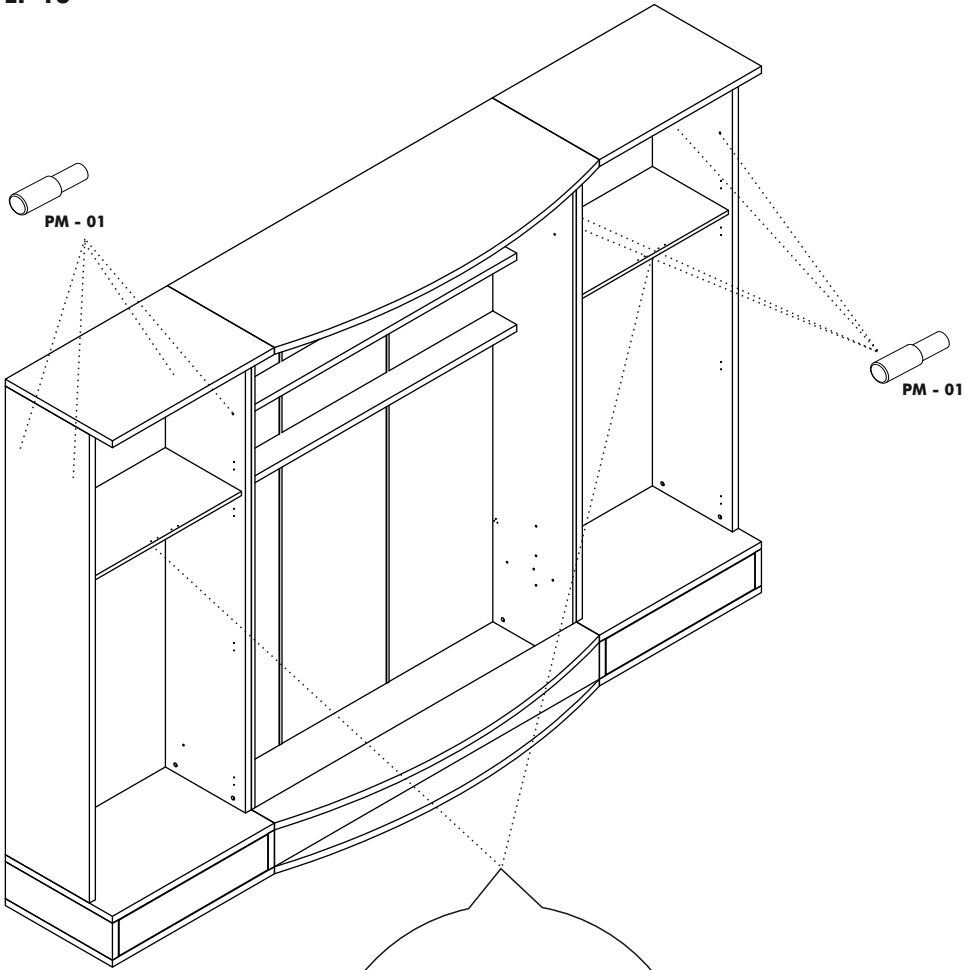

VIDEO

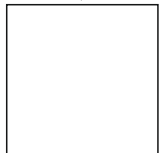

link

STEP 17

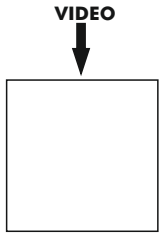
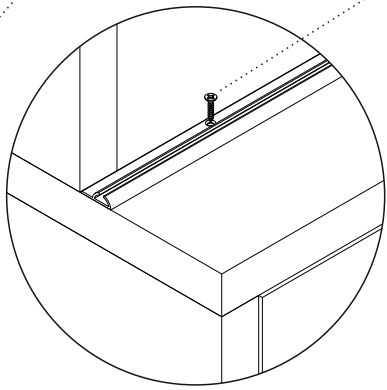
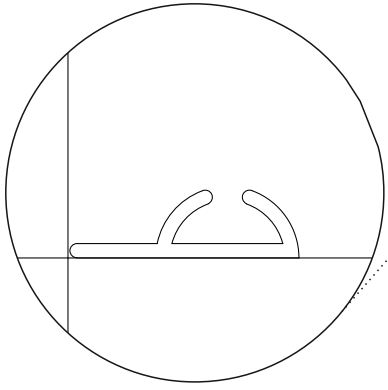
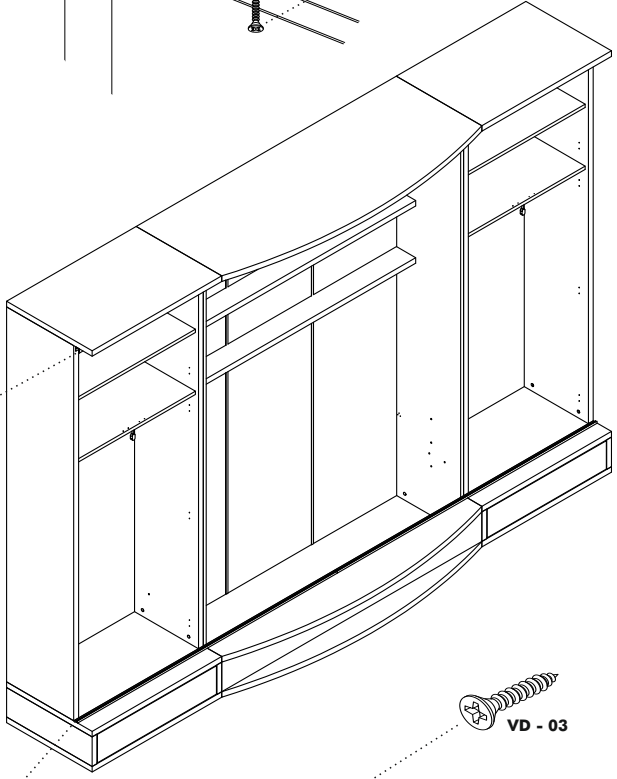
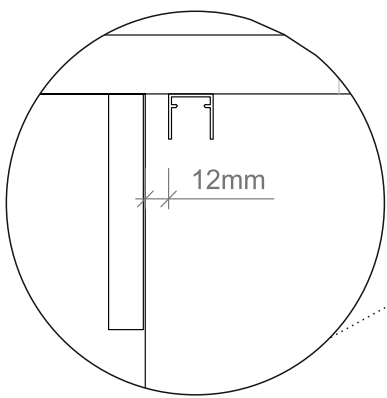
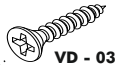
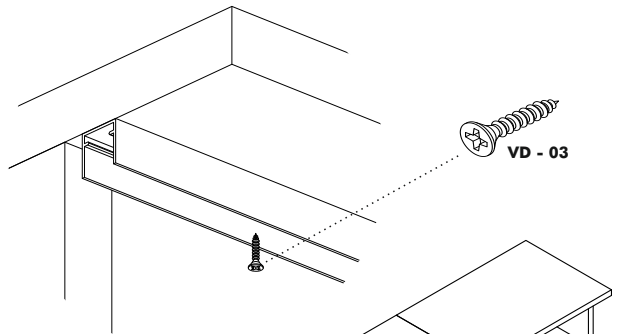

link

STEP 18

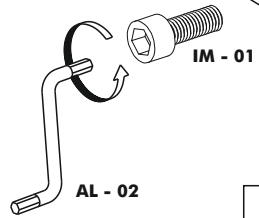
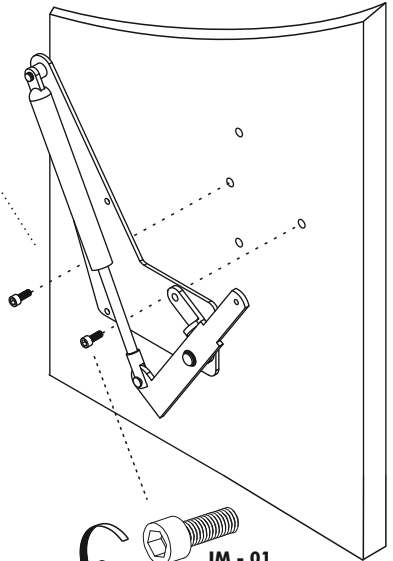
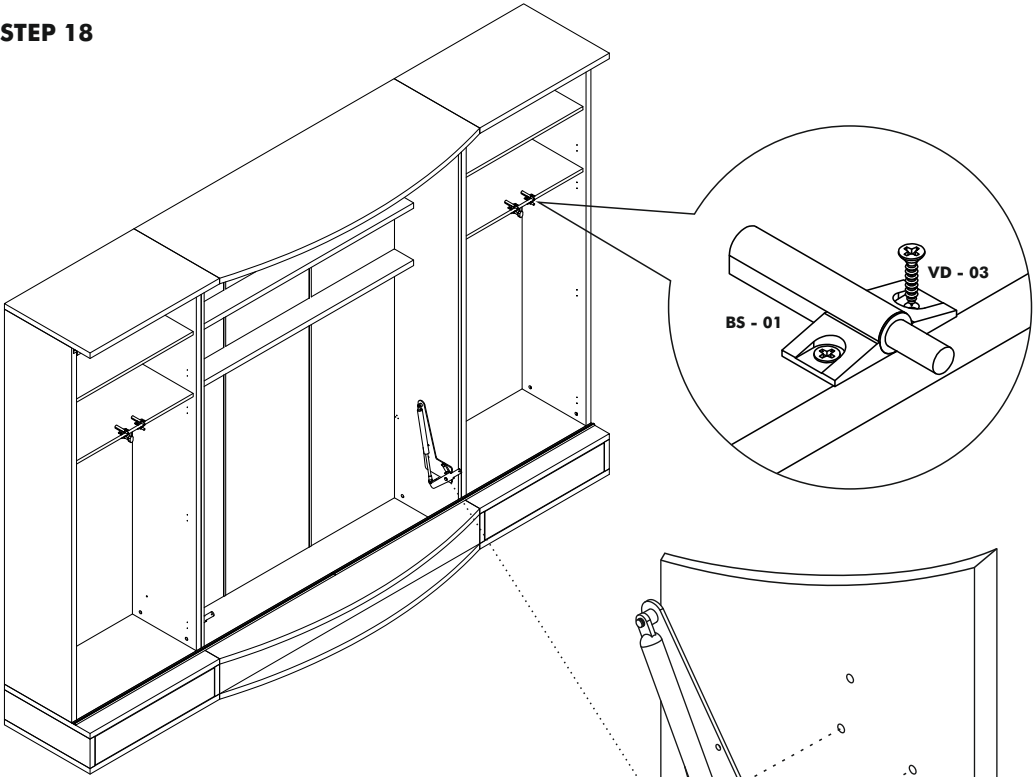

VIDEO

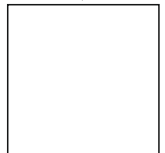

link

STEP 19

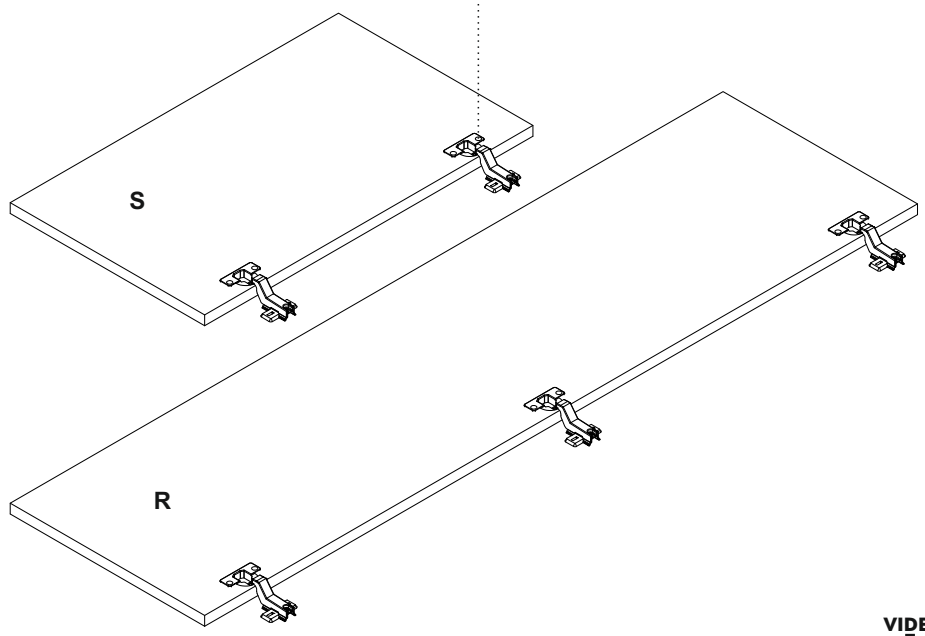
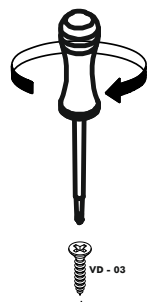
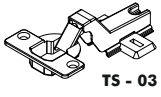

VIDEO

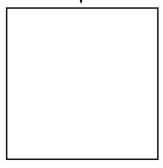

link

STEP 20

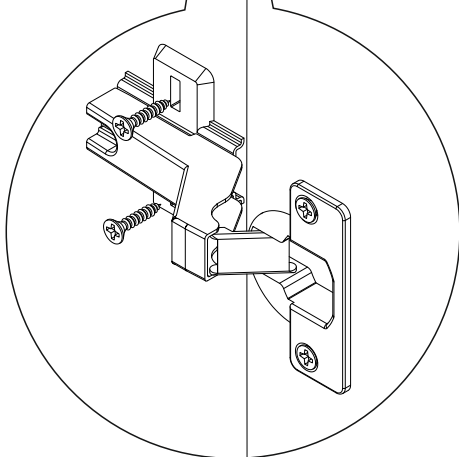
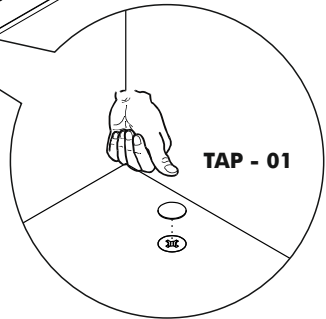
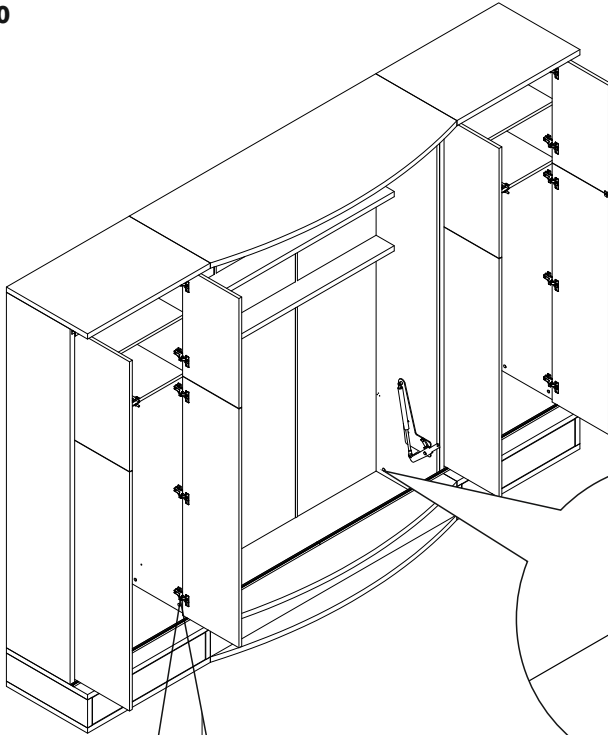

VIDEO

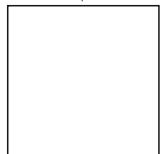

link

STEP 21

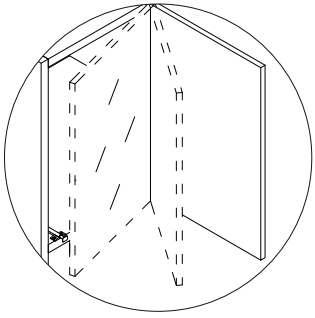
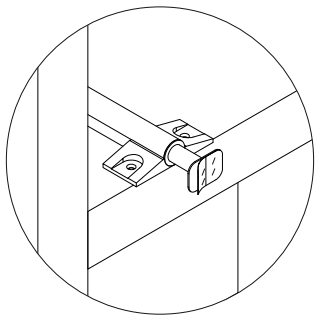
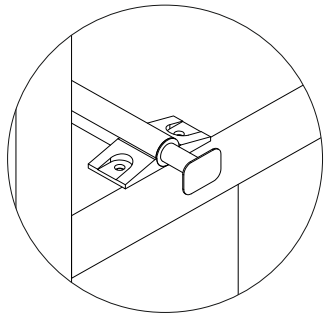
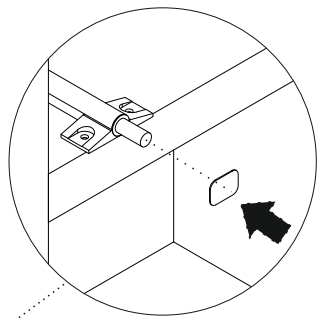
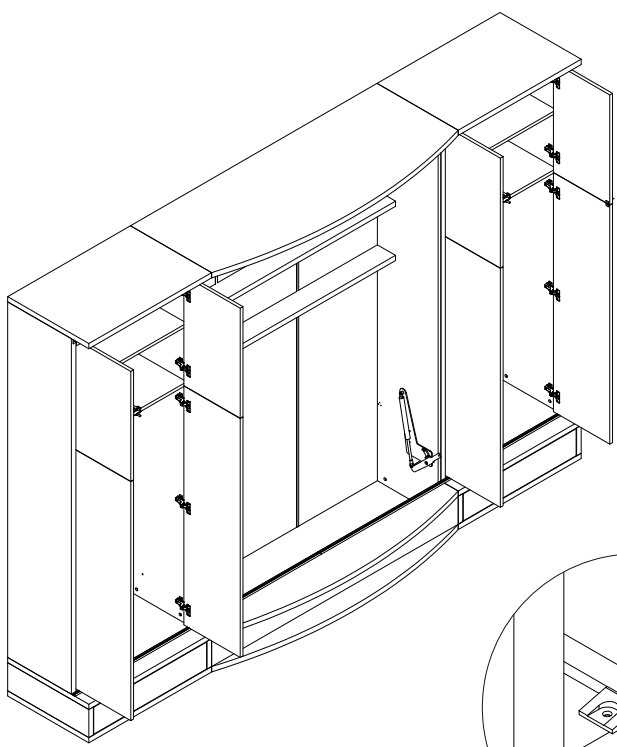

VIDEO

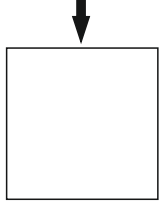

link

STEP 22

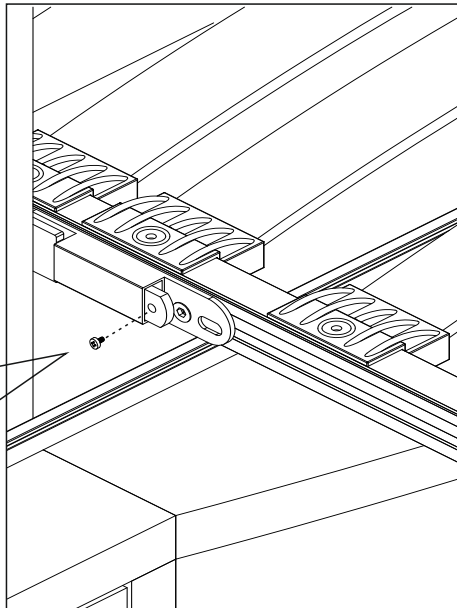
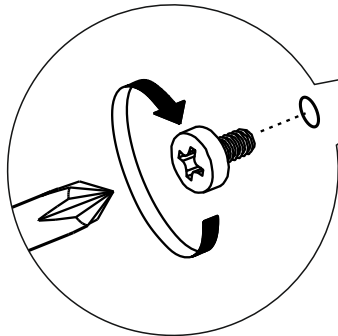
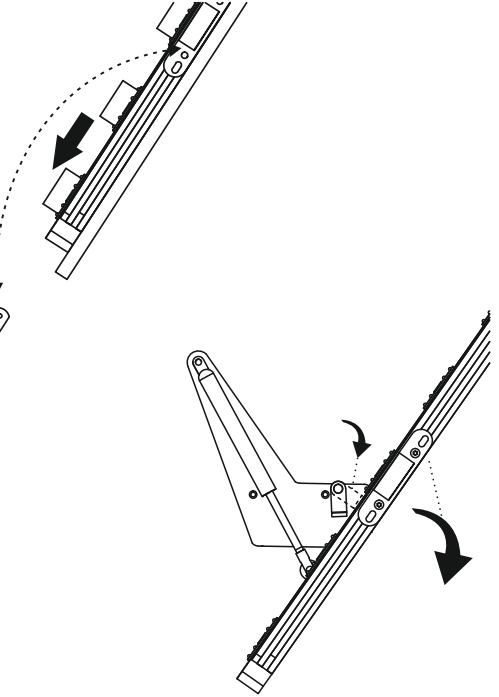
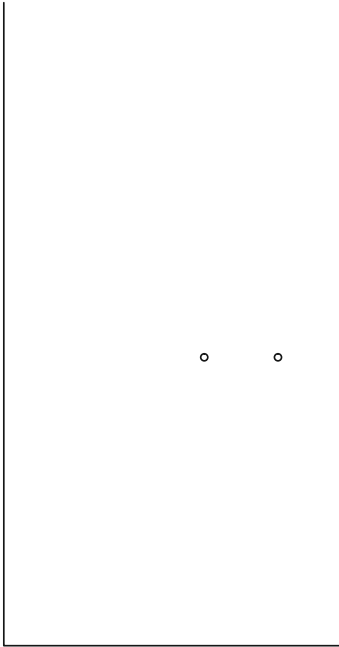

VIDEO

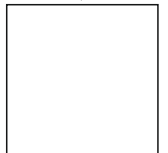

link

STEP 23

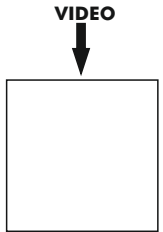
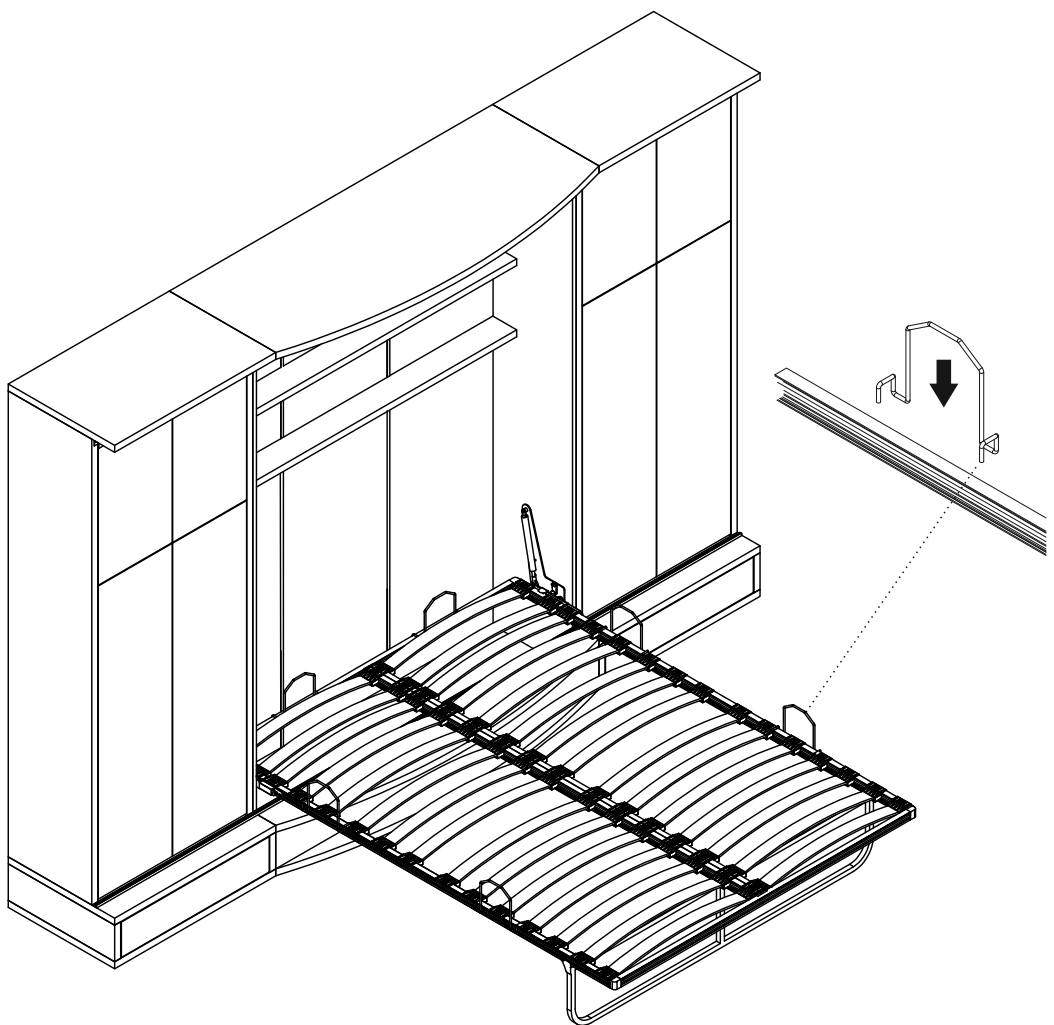

STEP 24

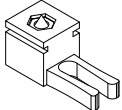

STP - 01

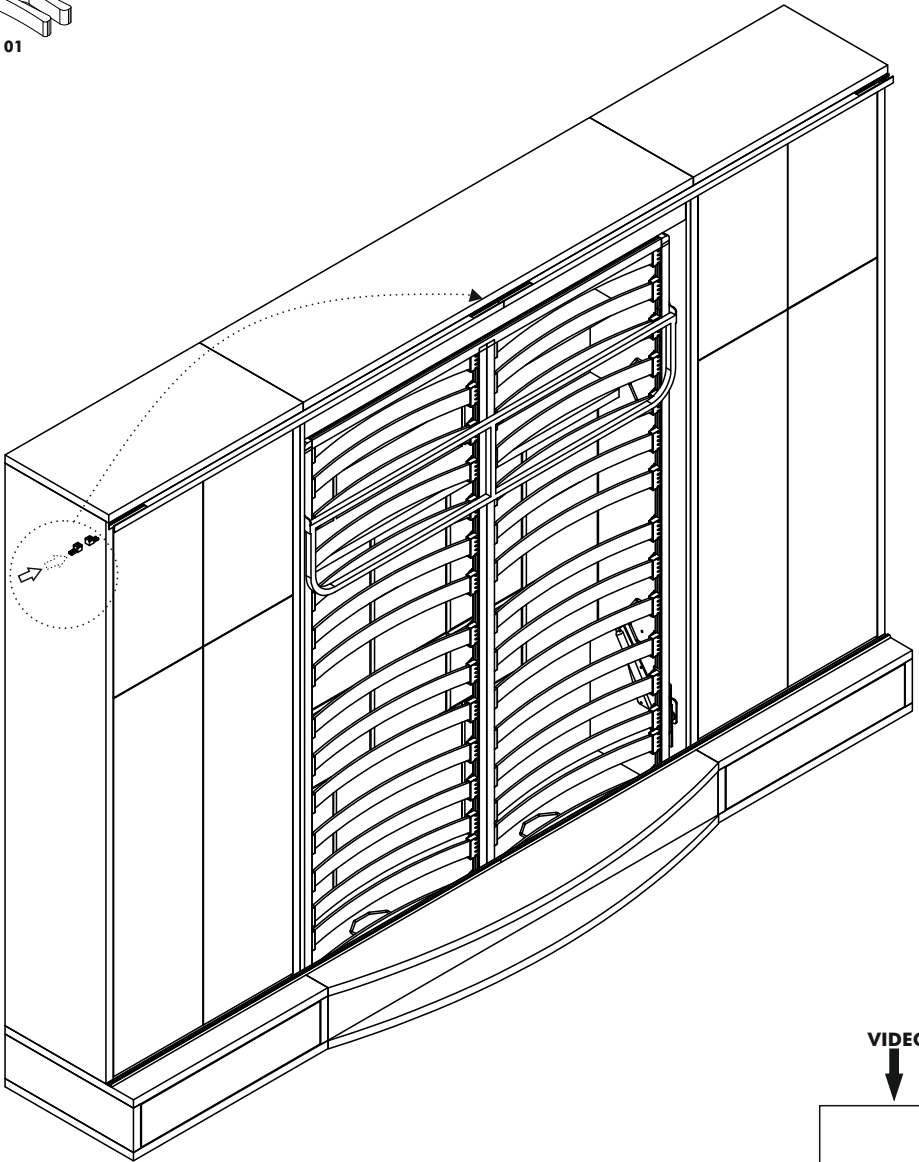

VIDEO

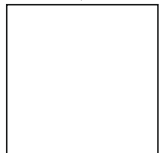

link

STEP 25

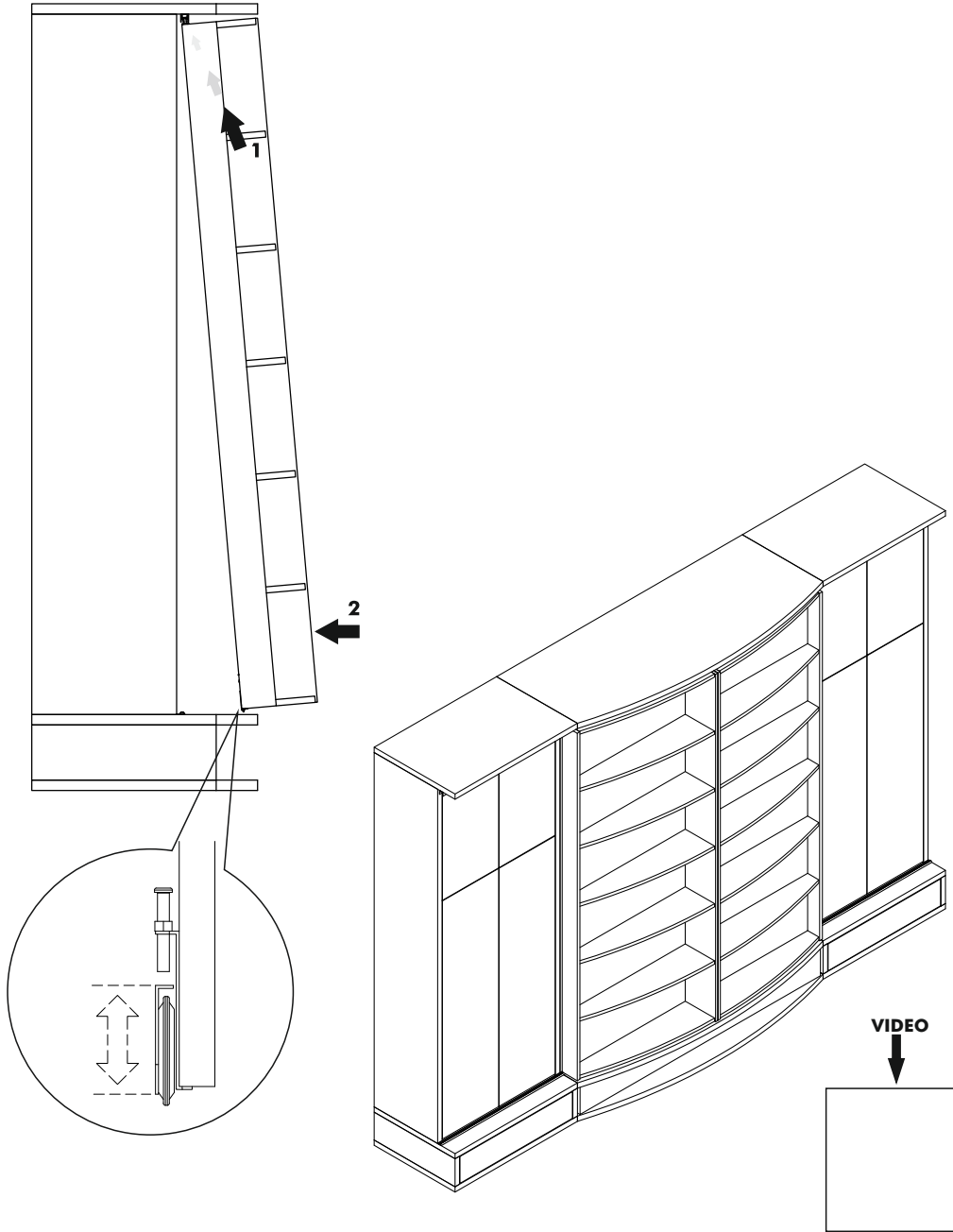

STEP 26

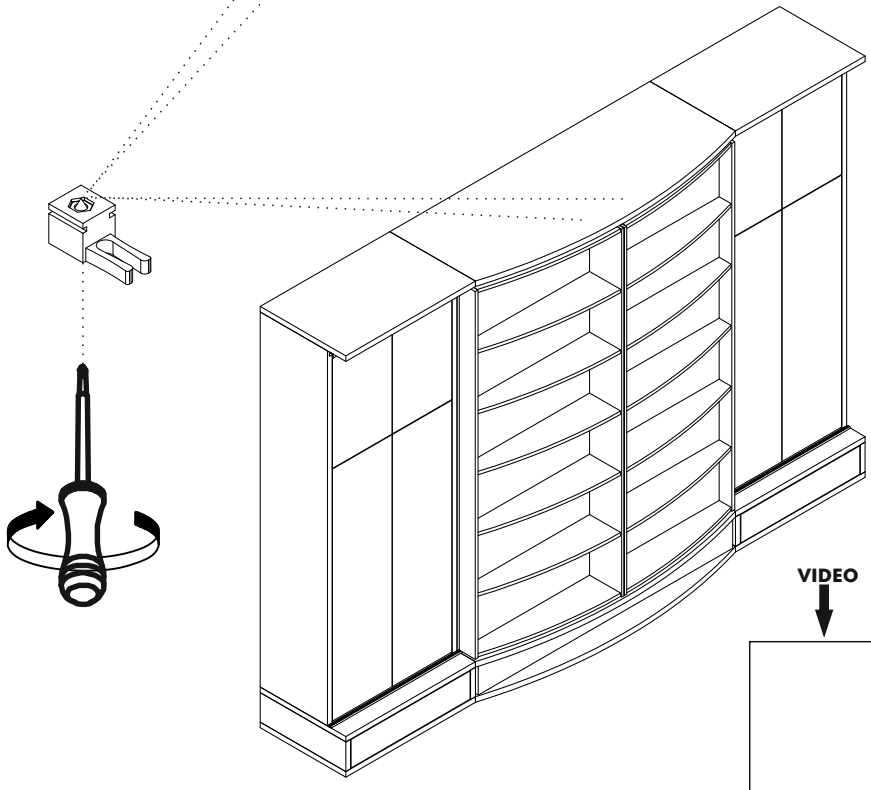
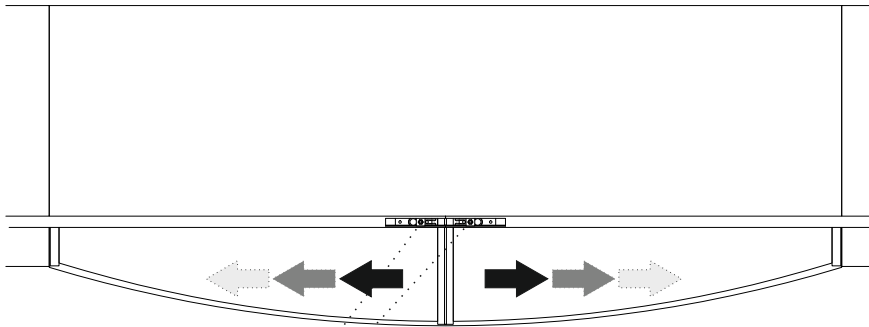
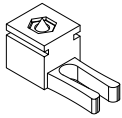

STEP 27

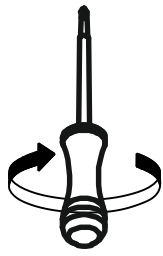
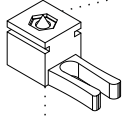
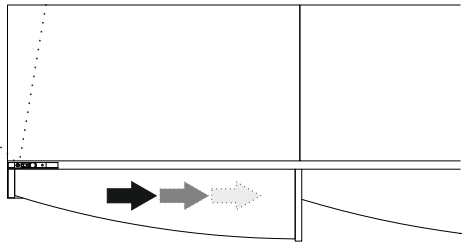
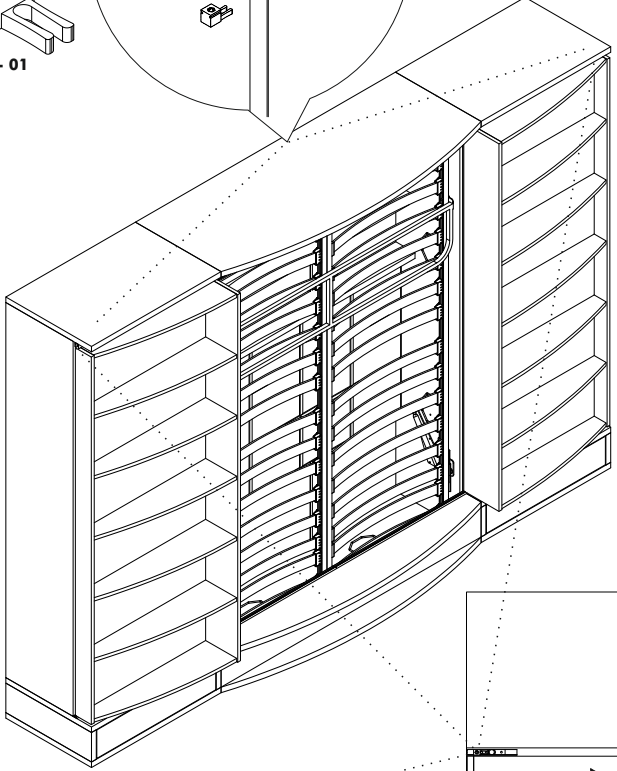
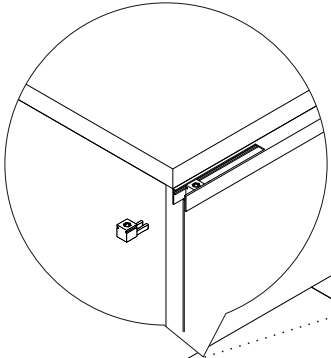
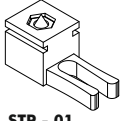

VIDEO

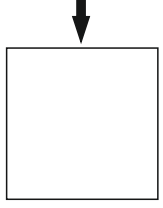

link



MULTiMO

www.multimo.com